

## Ficha Técnica



CÓDIGO	POTÊNCIA	LM	TENSÃO
565001RGB0J ° ku	50w	3750lm	220-240v

### ESPECIFICAÇÕES TÉCNICAS

Ângulo de abertura	120°
Temperatura de Cor	RGB+CCT
IRC	>80
LED Chip	SMD 2835
Sistema de Controlo	WIFI
Temperatura de trabalho	-20°/50°
Material	Aluminio + vidro
Acabamento	Preto
Dimensões	173x308x44mm
Certificados	CE&Rohs

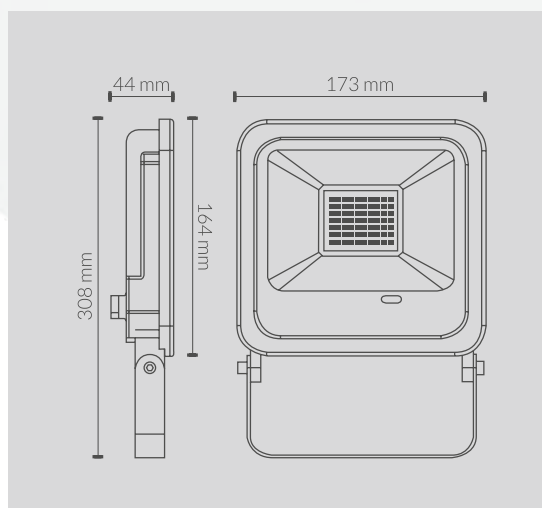

### ILUMINACION INTELIGENTE SMART LIGHTING / ILUMINAÇÃO INTELIGENTE



Compatible con: / Compatível com:

